



# RESTAURANT RANGE

6 Open Burners, Single Oven

A MIDDLEBY COMPANY

## 400 SERIES – All Models

- 33,000 BTU Burners
- 4" stainless steel front rail
- Commercial gas range 36-1/2" wide with a 36" high cooking top (including 6" high adjustable legs)
- 6 patented, clog-free, cast iron burners
- Cast iron grate top will hold a 14" stock pot
- Removable one-piece drip tray under burners
- Heat resistant door handle
- Stainless steel front, sides and removable shelf
- Porcelain enamel, lift-out oven bottom and coved interior
- Hinged lower valve cover

### Standard Oven (D Suffix)

- 45,000 BTU
- Single rack per oven
- Large 26" wide x 26-1/2" deep oven - full size sheet pans fit both ways
- Equipped with a flame failure safety device
- Thermostat range from 250°- 500°F (121°- 260°C) with low setting

### Convection Oven (A Suffix)

- 30,000 BTU
- Three racks per oven

## STANDARD OVENS 436D

## CONVECTION OVENS 436A



(shown with optional casters)

- Energy efficient flue design
- Fully front serviceable
- Manual pilot ignition, enamel bottom, and door linings
- On/Off switch to allow CO base to operate as Standard oven

## CONSTRUCTION SPECIFICATIONS

### All Models

- **Exterior Finish:** stainless steel front, sides and shelf standard.
- **Range Top:** 6 each cast iron burners round, non-clogging design, center-to-center measurements between burners not less than 12", side-to-side or front-to-back. A removable, one-piece tray is provided under burners to catch grease drippings.
- **Back Shelf:** Rigid single deck stainless steel.

### Standard Models (436DD)

- **Interior:** Cavity sides, top and back aluminized steel. Oven bottom and door lining porcelain enamel finish. Four sides and top of oven insulated with heavy, self-supporting block type rock wool with oven baffle assembly constructed of Aluma-Ti steel.
- **Rack and Rack Guides:** 2-position rack guides with one removable rack.
- **Door:** Constructed with heavy-duty hinges and unbreakable quadrants and heat resistant handle.
- **Controls:** Oven thermostat temperature type adjustable for 250°-500°F with a low setting.
- **Pressure Regulator:** Factory installed.

### Convection Models (436A)

- **Interior:** Cavity, bottom and door porcelain enamel finish. Back, top and sides aluminized steel. Four side and top of oven insulated with heavy, self-supporting, block type rock wool.
- **Rack and Rack Guides:** Heavy duty, 5 sets of rack guides on 2-3/8" centers with 3 removable plated racks. (For best results, no more than 3 racks should be used).
- **Door:** Constructed with heavy-duty hinges and unbreakable quadrants and heat resistant handle.
- **Blower Fan and Motor:** 1/3 hp, 1725 rpm, 60 cycle, 115V AC, high efficiency, permanent split phase motor with permanent lubricated ball bearings, overload protection and Class "B" insulation. Motor mounted to rear of oven. Motor serviceable from front of oven through oven cavity.
- **Electrical System:** Wired for single phase, 115V AC with 6' cord and 3-prong plug supplied with each deck.
- **Gas Control System:** Includes pressure regulator, flame switch safety, pilot filter, pilot adjustment.
- **Oven Heating:** Aluminized steel bar burner. Dual flow fan recirculates heat directly from combustion area and within oven cavity.
- **Controls:** Oven thermostat temperature type adjustable for 250°-500°F with a low setting.

Dimensions—in (mm)

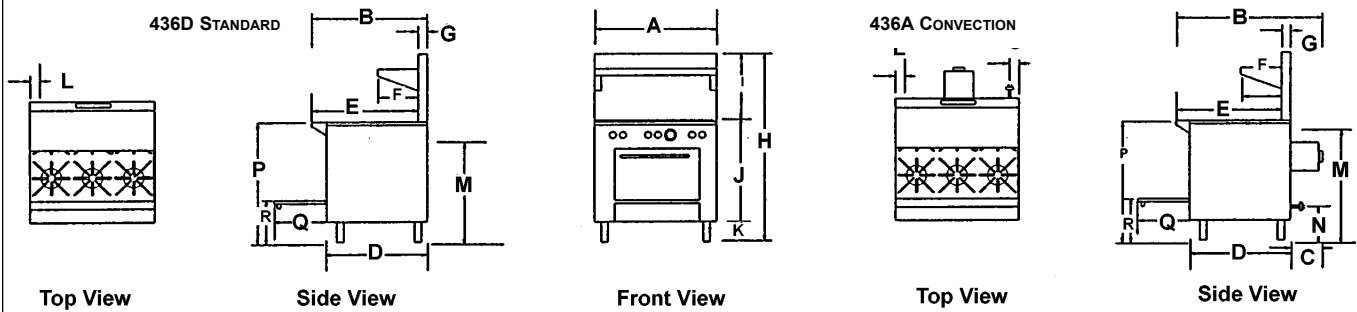

Model	Exterior											3/4" Gas Conn.		Electric		Cook Top P	Door Opening Q	Oven Bottom R
	A Width	B Depth	C	D	E	F	G	H Height	I	J	K	L	M	N	O			
436D	36.50" (927)	34" (864)	—	29.75" (756)	31.25" (794)	12" (305)	2.75" (70)	59.50" (1511)	22.50" (572)	31" (787)	6" (152)	1.50" (38)	30.25" (768)	—	—	37" (940)	15.5" (394)	13" (318)
436A	36.50" (927)	42.25" (1072)	8" (203)	29.75" (756)	31.25" (794)	12" (305)	2.75" (70)	59.50" (1511)	22.50" (572)	31" (787)	6" (152)	1.50" (38)	30.25" (768)	10.25" (260)	3.75" (95)	37" (940)	15.5" (394)	13" (318)

Model	Oven Interior			Burners (BTU each)			Crate Size			Cubic Volume	Crated Weight
	Width	Depth	Height	Griddle	Open	Oven	Width	Depth	Height		
436D	26" (660)	26.50" (673)	14" (356)	—	6 (33,000)	1 (45,000)	44" (1118)	45.5" (1156)	48" (1905)	55.6 cu.ft. (1.58 cu.m.)	535 lbs. (241 kg.)
436A	26.125" (664)	21.75" (552)	14.25" (362)	—	6 (33,000)	1 (30,000)	44" (1118)	45.5" (1156)	48" (1905)	55.6 cu.ft. (1.58 cu.m.)	535 lbs. (241 kg.)

NOTE: Dimension C on Model 436A includes 2" (50.8mm) minimum clearance between motor and wall.

UTILITY INFORMATION

Gas

- 436D: Total BTU-Nat: 243,000; LP: 184,000
- 436A: Total BTU-Nat: 228,000; LP: 174,000
- One 3/4" female connection. See drawing above for location.
- Required minimum inlet pressure:
  - Natural gas 7" W.C.
  - Propane gas 11" W.C.

Electric (436A only)

- Standard: 115/60/1 phase, furnished with 6' cord w/3-prong plug. Total maximum amps 4.8.
- Optional: 208/230, 50/60/1 or 3 phase. Supply must be wired to junction box with terminal block located at rear. Total maximum amps 2.6.

MISCELLANEOUS

- If using flex hose connector, the I.D. should not be smaller than 3/4" and must comply with ANSI Z 21.69.
- If casters are used with flex hose, a restraining device should be used to eliminate undue strain on the flex hose.
- For installation on combustible floors (with 6" - high legs) and adjacent to combustible walls, allow 6" (152 mm) clearance.
- Recommended - install under vented hood.
- Check local codes for fire and sanitary regulations.
- If the unit is connected directly to the outside flue, an A.G.A. approved down draft diverter must be installed at the flue outlet of the oven.
- Two speed motors are not available on Restaurant Range Convection Ovens.

NOTICE

Southbend reserves the right to change specifications and product design without notice. Such revisions do not entitle the buyer to corresponding changes, improvements, additions or replacements for previously purchased equipment.

OPTIONS AND ACCESSORIES

Inquire at the factory for special or custom requirements.

- |  |   |   |
|--|---|---|
| <input type="checkbox"/> 10" flue riser (no charge)  | <input type="checkbox"/> Hot Top plates - each plate replaces 2 Open burner section | <input type="checkbox"/> Auxiliary griddle plates   |
| <input type="checkbox"/> 3/4" quick disconnect with flexible hose complies with ANSI Z 21.69 (Specify 3 ft. 4 ft. 5 ft.) | <input type="checkbox"/> S-36 Salamander Radiant Broiler                            | <input type="checkbox"/> 12" griddle (Model 436-1G) |
| <input type="checkbox"/> Casters - all swivel - front with locks   | <input type="checkbox"/> CM-36" Cheese Melter                                       | <input type="checkbox"/> Extra oven racks           |
|  | <input type="checkbox"/> MRA-36 Infra-Red Salamander Broiler                        | <input type="checkbox"/> Stainless Steel rear panel |
|  |   | <input type="checkbox"/> Cabinet base               |

INTENDED FOR COMMERCIAL USE ONLY. NOT FOR HOUSEHOLD USE.



1100 Old Honeycutt Rd. Fuquay-Varina, NC 27526  
 800-348-2558 or 919-552-9161  
 (Fax) 800-625-6143 or 919-552-9798  
 www.southbendnc.com