



There's Always Something Cooking.

Model BNB Bread and Batter Cabinet

Project _____

Item number _____

Quantity _____

BNB



Model BNB

(Shown with optional pan slides, pans not included)

Standard Specifications

CONSTRUCTION

- Drain area allows for holding and raining of finished product.
- Optional oil drain opens to cabinet below.
- Drain screen easily lifts out for cleaning.
- Optional pan rack holds three (12" x 12" x 4") standard pans providing ample storage for breading, batter, food utensils, etc. Available only on models BNB14, BNBE14, BNB18, & BNBE18.
- Designed to match existing or accompanying fryer.
- Bread and Batter cabinet can be installed on either side of a fryer.
- Equipped with dual panel heavy gauge door for easy access to pan area.
- Steel cabinet and stainless steel front to match fryer. Mounted on adjustable legs.

NOTE

If Bread and Batter cabinet is ordered with stainless steel fryer, stainless steel exterior will be furnished unless otherwise specified.

Standard Accessories

- Non-removable 4-5/8 in (11.75 cm) recessed pan
- Bottom shelf
- Removable drain screen
- Basket hanger
- Cabinet - Stainless steel front, galvanized sides and back.

OPERATIONS

- Easily integrates into existing fryer combinations to provide a comfortable work area or food preparation station.
- Back mounted basket hanger for convenient basket storage.

Available Options & Accessories

- Flush work surface
- Stainless steel exterior
- Casters
- Cover
- Special cutouts available
- Foodwarmer / Heat Lamp
- Scoop pan liner (for scooping of french fries, etc.)
- Flat work surface
- Pan drain
- Pan slides

APPROVALS

- NSF Listed



Pitco Frialator, Inc., P.O. Box 501, Concord, NH 03302-0501 509 Route 3A, Bow, NH 03304, USA
Phone (800) 258-3708 (603) 225-6684 Fax (603) 225-8472 www.pitco.com



Model BNB - Bread and Batter Cabinet

Width, height, and depth dimensions are the same as those of the corresponding fryer model. Pan dimensions vary with size of unit, recess is the same on all units, recess is the same on all units.. Unit shown with optional caster.

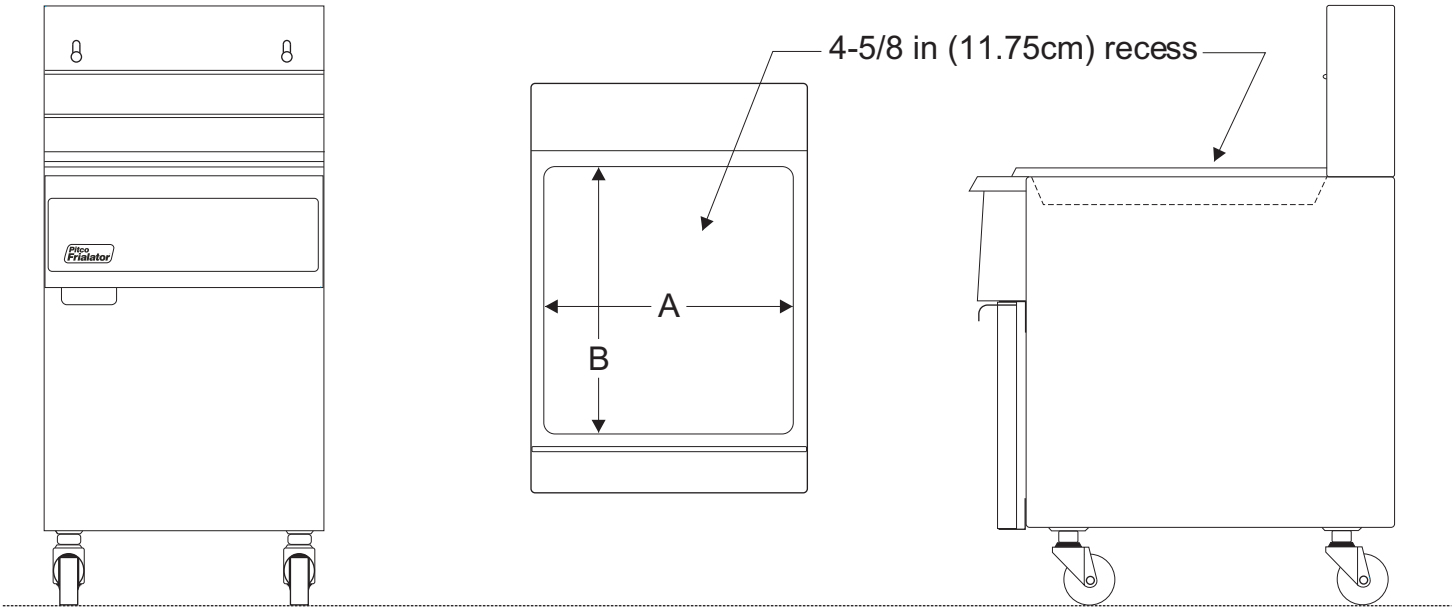

ORDERING INFORMATION		SHIPPING INFORMATION	
a. Specify model number of Bread and Batter cabinets desired. b. Specify which side of the fryer (when facing fryer) the Bread and Batter is to be placed. c. Any number of Bread and Batter units can be ordered in one cooking system. Channel strips between each set provide a custom appearance and sanitary joint. Specify arrangement desired.		Model BNB12D - 100 pounds (45.4 KG)/11.0 cu. ft. (0.31 M ³) Model BNBE12D - 100 pounds (45.4 KG)/11.0 cu. ft. (0.31 M ³) Model BNB(E)14 - 150 pounds (68.0 KG)/17.0 cu. ft. (0.48 M ³) Model BNBAG14 - 150 pounds (68.0 KG)/17.0 cu. ft. (0.48 M ³) Model BNB(E)18 - 175 pounds (79.4 KG)/23.0 cu. ft. (0.65 M ³) Model BNB(E)24 - 300 pounds (136.1 KG)/45.0 cu. ft. (1.27M ³) Model BNB(E)34 - 375 pounds (170.1 KG)/69.0 cu. ft. (1.95 M ³)	
CUTOUT DIMENSIONS			
Model Number	A	B	
BNB12D	12" (30.5 cm)	20 1/4" (54.4 cm)	
BNBE12A	12 1/2" (30.5 cm)	19 3/8" (46.7 cm)	
BNB(E)14	14" (35.6 cm)	23 5/8" (60.0 cm)	
BNBAG14	14" (35.6 cm)	19" (48.3 cm)	
BNB(E)18	18" (45.7 cm)	27 5/8" (70.2 cm)	
BNB(E)24	24" (61.0 cm)	24" (61.0 cm)	
BNB(E)34	34" (86.4 cm)	34" (61.0 cm)	
SHORT FORM SPECIFICATION			
Provide Pitco Model BNB Bread and Batter Cabinet. Bread and Batter Cabinet shall be a one piece cabinet constructed to match the dimensions of existing or new cooking equipment. Cabinet shall be supplied with removable drain screen, 4-5/8 in (11.75 cm) recessed pan and basket hanger. Provide accessories as follows.			
TYPICAL APPLICATION			
Provide a draining and holding area for finished product. Provide additional work area when used with optional flat or flush work surface.			

NOTE:
Model numbers BNB indicate cabinets used with gas cooking systems. Model numbers BNBE indicate cabinets used with electric cooking systems.

