



CH6, CH9 & CH18 COOK & HOLD CABINETS

CARTER-HOFFMANN



FOOD SERVICE EQUIPMENT
COOK & HOLD CABINETS

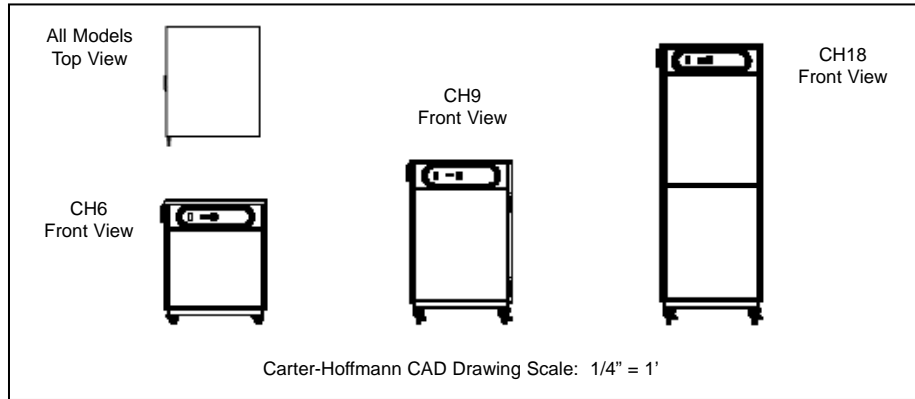

Model Number	Capacity 18"x26" Trays	Approximate Meat Capacity	Spacing		Inside Working Height		Overall Dimensions			Caster Diameter in mm	Shipping Weight					
			in	mm	in	mm	Height in mm	Depth in mm	Width in mm		lbs	kg				
<input type="checkbox"/> CH6	6	80 lbs	3	76	18 ¹ / ₈	460	38 ¹ / ₂	948	35 ¹ / ₄	895	24	610	5	127	312	142
<input type="checkbox"/> CH9	9	120 lbs	3	76	27 ¹ / ₄	692	47 ¹ / ₂	1207	35 ¹ / ₄	895	24	610	5	127	344	156
<input type="checkbox"/> CH18	18	240 lbs	3	76	54 ¹ / ₂	1384	78	1981	35 ¹ / ₄	895	24	610	5	127	460	209

CONSTRUCTION... Completely welded cabinet construction with outer cabinet welded to base. All seams turned in to eliminate raw edges.

CABINET MATERIAL... All stainless steel construction; 20 gauge polished exterior and 18 gauge interior.

BASE FRAME... 14 gauge stainless steel full depth caster bolsters with 14 gauge stainless steel perimeter supports welded to bolsters.

CASTERS... 5" diameter casters with rubber tread. Double ball bearing swivel. Zerk grease fittings. Plate mounted and bolted to base. Two casters fitted with brakes.

INSULATION... 2" thick high density continuous wrap-around type fiberglass insulation.

DOOR... Welded double panel stainless steel door; 20 gauge polished exterior and 20 gauge interior. Filled with 2" thick high density fiberglass insulation. Field reversible. Dutch doors are standard on CH18.

HINGES... Adjustable self-closing, edgemount hinges with chrome plate finish.

GASKET... High temperature silicone gasket mounted to cabinet.

LATCH... Heavy-duty edgemount latch with magnetic catch.

TRAY RACK ASSEMBLIES... Removable 16 gauge stainless steel tray racks with 18 gauge stainless steel angle slides. Slides welded to assemblies and spaced on 3" centers.

THERMOMETER... Digital thermometer with remote sensing bulb for cabinet operating temperature. Digital temperature displays in temperature window of current mode (cook or hold) by pushing "view actual temp" button.

CONTROLS... User-friendly digital controls with digital readout displays for settings. Master on/off switch with "start/cancel" button for cook cycles. Touchpad to view actual temperature. Separate controls & displays for cook temperature and hold temperature. Eighteen hour digital timer display shows cook temperature in count down mode during cook cycle. During hold cycle, automatically switches to count up.

HEATING SYSTEM... Top mounted blower heater for even heat distribution. High impedance protected, internally cooled fan motor. Full range thermostat and on/off switch with power indicating light and "start/cancel" button. Water pan in top of cabinet provides moderate passive humidification.

HEAT DUCT SYSTEM... Precision engineered interior heat duct system to provide gentle heat circulation throughout cabinet to caramelize roasts for less food shrinkage and more attractive appearance.

ELECTRICAL CHARACTERISTICS...

Model	Volts	Watts	Amps	Plug
CH6	240	4100	17.1	NEMA 6-20P
CH9	240	4100	17.1	NEMA 6-20P
CH18	240	6100	25.4	NEMA 6-30P

All models are 60hz, single phase.

PERFORMANCE... Capable of slow cooking to a maximum temperature of 325°F (161° C). Capable of holding at a range of 100°F (38°C) to 200°F (93°C). Preheat to 160°F (71° C) in approximately 25 minutes. Temperature variance less than 5°F (3°C), top to bottom.

ACCESSORIES/OPTIONS...

- Stacking kit for CH6/CH9 or CH6/CH9. CH6/CH stack available with legs only
- Legs in lieu of casters
- Menu card holder
- Tamper resistant fasteners
- Locking door latch
- 208 volt operation, all models
- 120 volt operation, CH6 & CH9 only
- Gray vinyl bumper set in channel on each side of cabinet
- Carving station with cutting board & warming lamp (CH6 only)

Specifications subject to change through product improvement & innovation.

CARTER-HOFFMANN

1551 McCormick Ave., Mundelein, IL 60060
(847) 362-5500 • (800) 323-9793 • Fax (847) 367-8981
www.carter-hoffmann.com

SPECIFICATIONS

Printed in U.S.A. H20 0109
Carter-Hoffmann is a trademark of Carter-Hoffmann LLC.





CH6, CH9 & CH18 COOK & HOLD CABINETS

Since 1947, Foodservice Equipment That Delivers!

CARAMELIZATION IS KEY... Precision engineered heating system with gentle, consistent blower heat caramelizes roasts and seals in juices for minimal shrinkage and more portions. And it produces a more natural, attractive product with superior taste.

REMOVABLE HEATING SYSTEM... Fully contained top mounted heating unit is removable for easy service. Heat is forced through an interior baffle for optimal air flow and even circulation throughout cabinet.

VENTILATION HOOD NOT REQUIRED... Because these cabinets cook at a lower temperature than standard convection ovens, a hood is not needed (check local codes).

ALL STAINLESS STEEL CONSTRUCTION... Welded, turned-in seam construction for long durable life and ease of cleaning and safety.



CH18
 (shown with optional side bumpers)



EASY-TO-USE DIGITAL CONTROLS... Control cooking and holding with separate dial controls and digital display. Temperature range of 100°F to 200°F for hold cycle and 100°F to 325°F for cook cycle. Eighteen hour timer counts down in cook cycle. When cook cycle is over, cabinet automatically switches to hold cycle and timer counts up.



CH6
 (shown with optional side bumpers)