



## MODEL DFG-50

Half-size Dual Flow Gas Convection Oven



Project \_\_\_\_\_

Item No. \_\_\_\_\_

Quantity \_\_\_\_\_

DFG-50

Standard depth baking compartment - accepts 13" x 18" standard half-size baking pans in front-to-back-position.

All data is shown per oven section, unless otherwise indicated.

### EXTERIOR CONSTRUCTION

- Full angle-iron frame
- Stainless steel front, top, sides and back
- Dual pane thermal glass window encased in stainless steel door frame
- Single chrome plated door handle
- Tilt-down modular front control panel
- Solid mineral fiber insulation at top, back, sides and bottom

### INTERIOR CONSTRUCTION

- Double-sided porcelainized baking compartment liner (14 gauge)
- Aluminized steel combustion chamber
- Dual inlet blower wheel
- Five chrome-plated racks, nine rack positions with a minimum of 15/8" (41mm) spacing
- Interior lights

### OPERATION

- Dual Flow Gas system combines direct and indirect heat
- Electronic spark ignition control system
- Removable dual tube burner
- Pressure regulator and manual gas service cut-off valve located in front control area
- Air mixers with adjustable air shutters
- Solid state thermostat with temperature control range of 200°F (93°C) to 500°F (260°C)
- Single speed fan motor
- 1/3 horsepower blower motor with automatic thermal overload protection
- One control area cooling fan

### STANDARD FEATURES

- Solid state manual with separate dials to control thermostat and timer
- Two year parts and labor warranty\*
- Five year door warranty\*

\* For all international markets, contact your local distributor.

### OPTIONS AND ACCESSORIES

(AT ADDITIONAL CHARGE)

- **Control options:**
  - Pulse Plus®
  - Cook & hold
  - Solid State digital control with LED display, cook and hold, and PulsePlus®
  - CHPro3 - Programmable solid state digital control with LED display, cook and hold, Pulse Plus®, 3 program product keys
- **Legs/casters:**
  - 4" (102mm) black legs
  - 6" (152mm) casters
- **Stands:**
  - 5-3/4" (146mm) stainless steel stand
  - 7" (178mm) stainless steel stand (not for use with casters)
  - 16" (406mm) stainless steel stand
  - 19" (483mm) stainless steel stand with shelf
  - 24" (610mm) stainless steel stand with shelf
  - 33" (838mm) stainless steel stand with shelf
- **Venting:**
  - Draft diverter
  - Draft hood
- **Gas hose with quick disconnect and restraining device:**
  - 48" (1219mm) hose
  - 36" (914mm) hose
- Right hand hinged door
- Extra oven racks

### OPTIONS AND ACCESSORIES

(AT NO CHARGE)

- Solid stainless steel doors
- Stainless steel oven liner



### BLODGETT OVEN COMPANY

www.maytagfoodservice.com

50 Lakeside Avenue, Burlington, VT 05402

Toll Free: (800) 331-5842 • Phone: (802) 860-3700 • Fax: (802) 864-0183

**MODEL DFG-50**

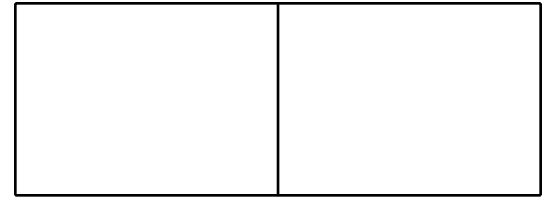

**APPROVAL/STAMP**

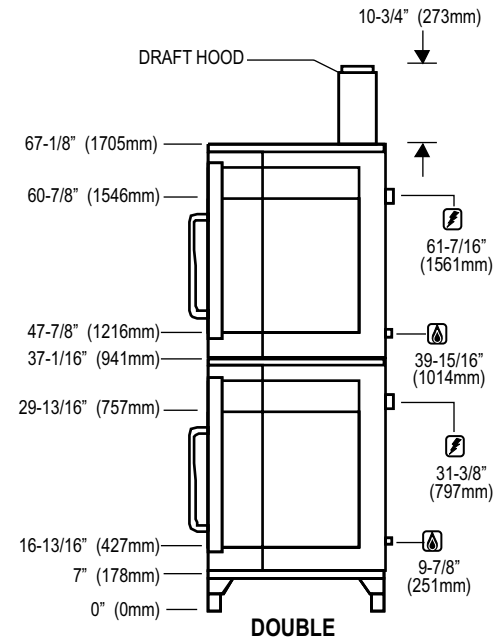
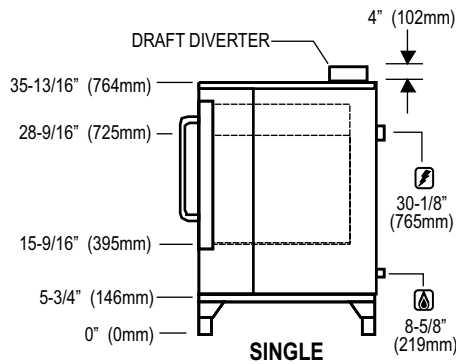
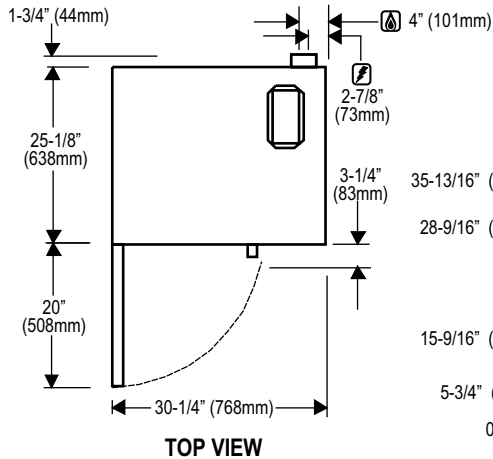

**SHORT FORM SPECIFICATIONS**

Provide Blodgett half-size convection oven model DFG-50, (single/double) compartment. Each compartment shall have (porcelainized/stainless) steel liner and shall accept five 13" x 18" standard half-size bake pans. Stainless steel front, top, back and sides. Doors shall (be solid stainless steel have dual pane thermal glass windows) with single chrome plated door handle. Unit shall have an electronic spark ignition control system and removable dual tube burner with air mixers and adjustable air shutters. Dual Flow Gas system combines direct and indirect heat and has a 1/3 horsepower blower motor with automatic thermal overload protection and dual inlet blower wheels. Each chamber shall be fitted with five chrome-plated removable racks, and have nine rack positions. Control panel shall be recessed with Cook/Cool Down mode selector, solid state (manual/digital) infinite thermostat (200° - 500°F), and 60 minute timer. Provide options and accessories as indicated.

**DIMENSIONS:**

**Floor space** 30-1/4" (782mm) W x 25-1/8" (638mm) D  
**Product clearance** 6" from combustible and non-combustible construction  
**Interior** 15-3/8" (390mm) W x 20" (508mm) H x 21" (533mm) D

**GAS SUPPLY:**

3/4" NPT Single/Double  
 Manifold Pressure:  
 • Natural – 3.5" W.C. • Propane – 10" W.C.  
 Inlet Pressure:  
 • Natural – 7.0" W.C. min. – 10.5" W.C. max.  
 • Propane – 11.0" W.C. min. – 13.0" W.C. max.

**MAXIMUM INPUT:**

Single 27,500 BTU/hr  
 Double 55,000 BTU/hr

**NOTE:** The company reserves the right to make substitutions of components without prior notice

**POWER SUPPLY:**

**Domestic:**  
 2-wire w/grd., 5 Amp, 115 VAC, 1 phase, 60 Hz. 1/3 H.P., 1 speed motor, 1725 RPM  
**International:**  
 2-wire w/grd., 6 Amp, 220/240VAC, 1 phase, 50 Hz. 1/3 H.P., 1 speed motor, 1725 RPM

6' (1.8m) electric cord set furnished on 115 VAC ovens only.

**MINIMUM ENTRY CLEARANCE:**

Uncrated 28" (711mm)  
 Crated 32-1/2" (914mm)

**SHIPPING INFORMATION:**

<b>Approx. Weight:</b>	<b>Crated</b>	<b>Uncrated</b>
Single	300 lbs. (136 kg)	265 lbs. (120 kg)
Double	600 lbs. (272 kg)	530 lbs. (240 kg)

**Crate sizes:**

32-1/2" (826mm) x 36" (914mm) x 34-1/2" (645mm)

**BLODGETT OVEN COMPANY**

www.maytagfoodservice.com

50 Lakeside Avenue, Burlington, VT 05402

Toll Free: (800) 331-5842 • Phone: (802) 860-3700 • Fax: (802) 864-0183