



MarineSeries

Item No. _____
Project _____
Quantity _____

Electric, One-Pan Marine Deck Ovens

Model: D036_M

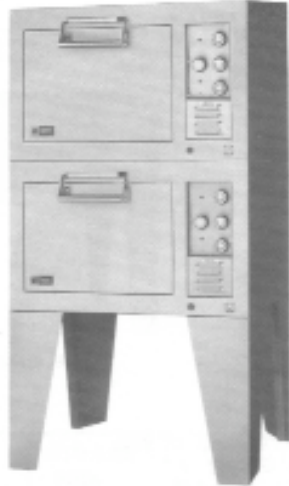

Model D0362M shown

PAN & PRODUCTION CAPACITY GUIDE

Model:	18" x 26" Full-Sheet	Pies - 9	Bread - 1-lb. Loaves
D0361M/D036M	1	6	10
D0362M	2	12	20
D0363M	3	18	30

MARINE SHORT/BID SPECIFICATION

Deck Oven[s] shall be LANG Manufacturing Model D036__ [Insert 1, 2, 3 OR D036M] , a 6-kW [each] electric heated single-pan deck oven, with: space saving 36" overall width; solid, spring loaded pull-down door; all stainless steel exterior; insulated, aluminized steel oven interior, with top and bottom mounted Incoloy-sheathed heating elements; one heavy duty pan rack standard; stainless steel angular legs [except LA36SM Model].

MARINE PRODUCT WARRANTY

One year, parts & labor (Labor in U.S. only)

MARINE CONSTRUCTION FEATURES

- Heavy duty 430 Series stainless steel exterior
- Aluminized steel oven interior fully insulated on six sides
- Heavy duty spring-loaded pull-down door with grab-bar handle
- Recessed, right side mounted control panel
- 27" [Single Deck], 16" [Double Deck] or 6" high [Triple Deck] stainless legs standard
- One heavy duty wire rack provided, per oven/deck

PERFORMANCE FEATURES

- Hatchable modular design allows movement through 26" X 66" watertight hatch
- Top & bottom mounted Incoloy sheathed heating elements
- Stackable up to three high, for more capacity in same footprint
- Reinforced oven deck eliminates warping
- Sturdy pull-down door serves as loading platform
- 175-550°F operating temperature range

CONTROL PACKAGE [Per deck]

- Recessed control panel, in the cool zone
- 150-450°F thermostat temperature control
- 3-heat switch for: top only, bottom only or top & bottom heat
- 1-hour timer with loud buzzer



Sheet No. LMSP-D1 (rev. 07/07)



Electric, One-Pan Marine Deck Ovens

Model: D036_M

MARINE INSTALLATION REQUIREMENTS

- (E) 208V or 240V, 1-Phase or 3-Phase power required; or standard 440V/480V, 3-Phase
- Consult marine codes for installation requirements
- Multi-deck ovens ship separate [For movement through watertight hatch] Assembly hardware provided.
- [Power connection from bottom. See below]

MARINE OPTIONS & ACCESSORIES

- Stainless steel interior oven compartment
- Extra wire pan racks [one provided as std., per oven/deck]

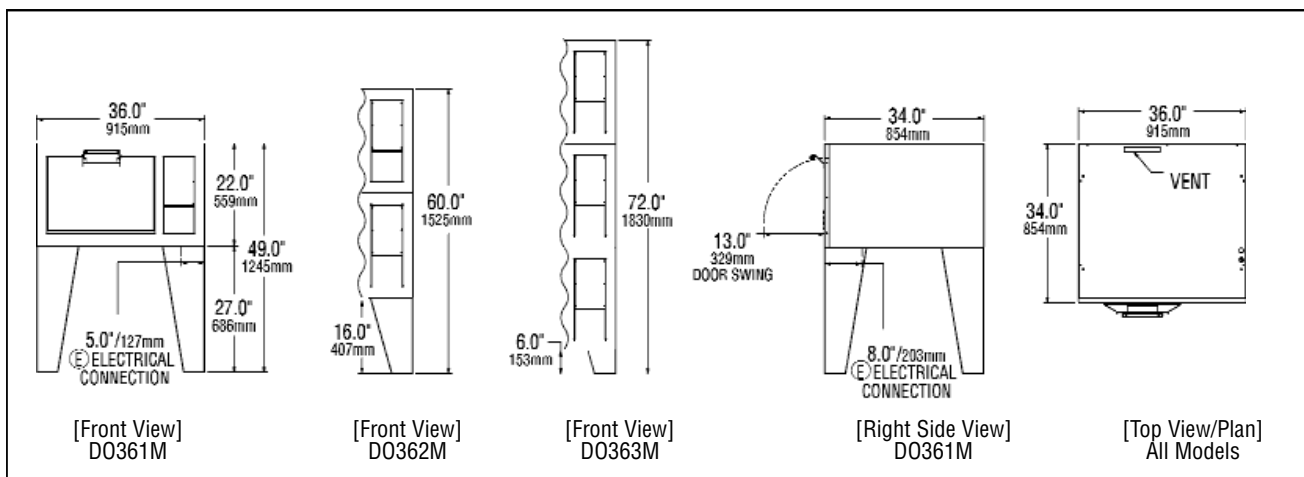

Model	Height x Width x Depth (without legs)		Clearance from combustible surface*	Weight		Freight Class
	External	Inside Oven Dimension		Actual	Shipping	
D036M	22.0" x 36.0" x 34.0" 559mm x 915mm x 854mm	12.0" x 22.0" x 27.8" 305mm x 559mm x 705mm	Sides: 2.0" (51mm) Back: 2.0" (51mm)	185 lbs. 84 kg	235 lbs. 107 kg	85
D0361M	22.0" x 36.0" x 34.0" 559mm x 915mm x 854mm	12.0" x 22.0" x 27.8" 305mm x 559mm x 705mm	Sides: 2.0" (51mm) Back: 2.0" (51mm)	235 lbs. 107 kg	285 lbs. 130 kg	85
D0362M	44.0" x 36.0" x 34.0" 1118mm x 915mm x 854mm	12.0" x 22.0" x 27.8" 305mm x 559mm x 705mm	Sides: 2.0" (51mm) Back: 2.0" (51mm)	470 lbs. 214 kg	520 lbs. 236 kg	85
D0363M	66.0" x 36.0" x 34.0" 1676mm x 915mm x 854mm	12.0" x 22.0" x 27.8" 305mm x 559mm x 705mm	Sides: 2.0" (51mm) Back: 2.0" (51mm)	680 lbs. 309 kg	730 lbs. 332 kg	85

* Noncombustible floor only.

Model	Volts AC - Hz	Total kW	Amps - Three Phase	Amps - Single Phase
D036M D0361M	208 - 50/60	6.0	N/A	28.9
	240 - 50/60	6.0	N/A	25.0
	440 - 50/60	5.0	N/A	11.5
	480 - 50/60	6.0	N/A	12.6
D0362M	208 - 50/60	12.0	50.0	57.7
	240 - 50/60	12.0	43.3	50.0
	440 - 50/60	10.1	19.9	N/A
	480 - 50/60	12.0	21.7	N/A
D0363M	208 - 50/60	18.0	50.0	86.5
	240 - 50/60	18.0	43.3	75.0
	440 - 50/60	15.1	19.9	N/A
	480 - 50/60	18.0	21.7	N/A

Due to continuous improvements, specifications subject to change without notice.



Sheet No. LMSP-D1 (rev. 07/07)

LANG MANUFACTURING - A DIVISION OF STAR MANUFACTURING INT'L, INC. • 10 SUNNEN DR. ST. LOUIS, MO 63143
TOLL FREE: 800.264-7827 • FAX: 314-781-3636 • www.langworld.com