



PIZ6

PIZ6 Series ovens

Doyon PIZ series is designed like no other on the market. Our exclusive Jet Air baking technology is a reversing fan system that helps to bake evenly. It has 3 individual drop down doors that only takes up to 6" (152 mm) in front of the oven.

PIZ ovens are great for space and energy savings. The 3 perforated nickel plated decks are designed for fast heat accumulation as well as even heat distribution across the decks. The heat provided from the nickel coated perforated deck makes a nice even crust due to the air moving through the perforated holes and from the heat of the metal deck itself.

Better known for baking pizzas, it can also be used to bake and cook multiple products.

VERSATILITY

Pizzas, sandwiches, italian, mexican, wing, seafood, poultry, pretzels, pastries, cajun, deserts and bakery items.

PIZ6

"Superior *quality* product
at an *affordable* price !"

Jet Air Pizza Oven

Standard Features

- Multipurpose oven
- Temperature up to 600 °F (315 °F)
- Fast baking
- Exclusive patented reversing fan system
- Preheats in 15 to 20 minutes
- Large baking capacity (3 baking decks)
- Baking surface : 3 decks of 37 3/4" W X 22" D (958 mm X 559 mm)
- Digital reminder timer
- Stainless steel inside and outside
- Direct baking on nickel coated perforated decks (pizza)
- 5 1/2" X 40" (140 mm X 1016 mm) door opening
- Heavy duty doors with full view thermos glass
- Easy cleaning
- Brightly lit
- Available gas or electric
- 3/4 HP motor
- ETL & NSF listed
- One year parts and labor limited warranty

OPTIONAL

- Stand on swivel casters (2 locking) (PIZ6B)
- Steam option (electric models only)
- 3 extra digital reminder timers
- 6 extra digital reminder timers
- CE listed models available on request
- Gas quick disconnect kit (4' (1220 mm) flexible hose, ball valve and securing device)

DIMENSIONS

PIZ6	47 5/8"W	X 44 7/8"D	X 36 1/4"H
	(1210 mm)	X 1140 mm	X 921 mm)
PIZ6G	47 5/8"W	X 47"D	X 36 1/4"H
	(1210 mm)	X 1194 mm	X 921 mm)

INTERIOR DIMENSIONS

PIZ6	39 3/4"W	X 25"D	X 21"H
	(1010 mm)	X 635 mm	X 533 mm)
PIZ6G	39 3/4"W	X 24"D	X 21"H
	(1010 mm)	X 610 mm	X 533 mm)

GAS SYSTEM (PIZ6G - Natural or propane)

BTU total : 70 000 BTU
 120V - 1 PH - 12 A - 1.4 kW - 2 wires - 60 Hz NEMA 5-15P
 Gas inlet : 1/2" NPT
 Draft hood : 4" (102 mm)

Recommended gas pressure:

Propane gas : 11" W.C.
 Natural gas : 7" W.C.

ELECTRICAL SYSTEM

PIZ6:
 120/208V - 3 PH - 43 A - 13.5 kW - 4 wires - 60 Hz
 120/240V - 1 PH - 56 A - 13.5 kW - 3 wires - 60 Hz
 220V - 1 PH - 68 A - 15 kW - 2 wires - 50 Hz

PRODUCTION PER HOUR(500°F/260°C - 5 min)

60 - 18" Pizzas
 90 - 14" Pizzas
 90 - 12" Pizzas
 180 - 9" Pizzas
 240 - 6" Pizzas

SHIPPING WEIGHT

PIZ6 : 875 lb (397 kg) approximately
 PIZ6G : 875 lb (397 kg) approximately
 PIZ6B : 135 lb (61 kg) approximately

Electrical inlet located at the back of the unit.
 Specifications and design subject to change without notice.

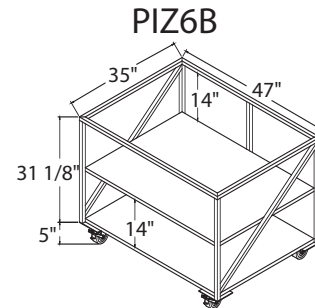
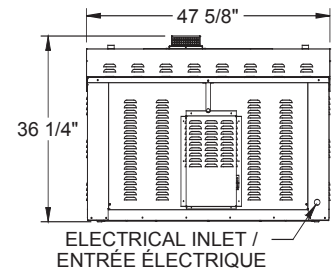
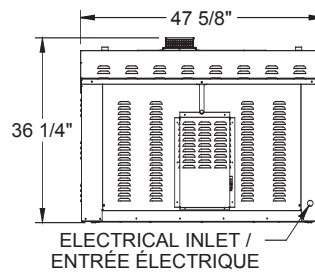
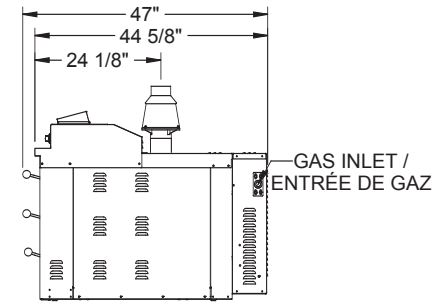
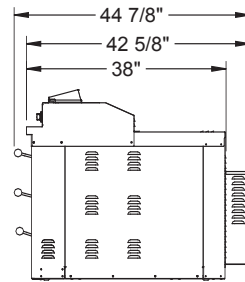
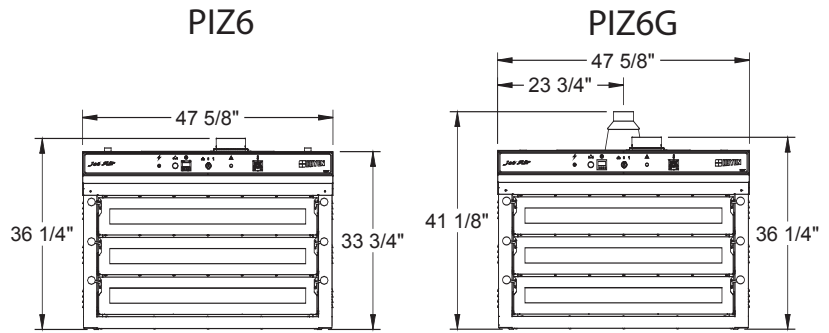

Your local distributor:

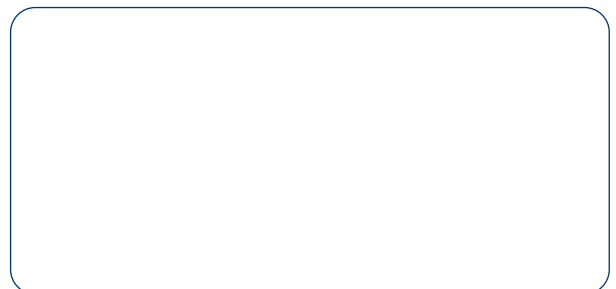

1255, rue Principale
 Linière, Beauce, Québec, Canada G0M 1J0

Telephone : (418) 685-3431 Fax: (418) 685-3948
 Canada : (800) 463-1636 U.S.: (800) 463-4273
 E-Mail : doyon@doyon.qc.ca Internet: http://www.doyon.qc.ca